

## The Original 6-Flute Chatterless-Countersinks™

Developed by Severance Tool, the flutes of the 6-flute Chatterless-Countersinks™ are designed with staggered cutting angles to eliminate the harmonics that cause chatter in conventional tools. Our tools feature a positive shearing action, are designed to take heavy cuts and produce exceptionally smooth seats. These six fluted countersinks give long service life because the cutting load is distributed over six cutting edges.

Use them in your milling machine, drill press, screw machine, lathes, automatics, special machines, feed units, and hand tools. See also page 53-54 for our CNC-K™ Chatterless-Countersinks™ for CNC lathes and Machining Centers. Our countersinks may be factory resharpened many times, see pages 89-90.

Available in a wide range of standard angles and sizes, or submit your request for special angles, diameters, double angles, pilots, or radii to our Engineering Dept.

### High Speed Steel

**We're The Originators! We've Been "Copied" But Not Surpassed.**

Head Dia.	Shank Dia.	Overall Length	Shank Length	Centerline Angle						
				30°	41°	45°	50°	55°	60°	
				Included Angle	60°	82°	90°	100°	110°	120°
Severance Name	Order Number	Order Number	Order Number	Order Number	Order Number	Order Number				
1/8"	1/8"	1-5/8"	1-5/8"	CK-1/8	02370	02390	02410	02430	02450	02470
3/16"	3/16"	1-1/2"	1-1/2"	CK-3/16	02371	02391	02411	02431	02451	02471
1/4"	3/16"	1-1/2"	3/4"	CK-1/4	02372	02392	02412	02432	02452	02472
5/16"	1/4"	1-3/4"	7/8"	CK-5/16	02373	02393	02413	02433	02453	02473
3/8"	1/4"	1-3/4"	7/8"	CK-3/8	02374	02394	02414	02434	02454	02474
1/2"	3/8"	2-1/8"	1-1/8"	CK-1/2	02375	02395	02415	02435	02455	02475
1/2"	1/4"	2-1/8"	1-1/8"	CK-1/2-1/4	02376	02396	02416	02436	02456	02476
5/8"	3/8"	2-3/8"	1-1/8"	CK-5/8	02377	02397	02417	02437	02457	02477
5/8"	1/4"	2-3/8"	1-1/8"	CK-5/8-1/4	02378	02398	02418	02438	02458	02478
3/4"	1/2"	2-11/16"	1-5/16"	CK-3/4	02379	02399	02419	02439	02459	02479
7/8"	1/2"	2-13/16"	1-5/16"	CK-7/8	02380	02400	02420	02440	02460	02480
1"	1/2"	2-13/16"	1-5/16"	CK-1	02381	02401	02421	02441	02461	02481
1-1/4"	3/4"	3-3/8"	1-5/8"	CK-1-1/4	02382	02402	02422	02442	02462	02482
1-1/2"	3/4"	3-1/2"	1-5/8"	CK-1-1/2	02383	02403	02423	02443	02463	02483
1-3/4"	1"	4-1/4"	2-1/8"	CK-1-3/4	02384	02404	02424	02444	02464	02484
2"	1"	4-3/8"	2-1/8"	CK-2	02385	02405	02425	02445	02465	02485
2-1/2"	1"	4-3/4"	2-1/8"	CK-2-1/2	02386	02406	02426	02446	02466	02486
3"	1"	5"	2-1/8"	CK-3	02387	02407	02427	02447	02467	02487

### Carbide

Head Dia.	Shank Dia.	Overall Length	Shank Length	Centerline Angle						
				30°	41°	45°	50°	55°	60°	
				Included Angle	60°	82°	90°	100°	110°	120°
Severance Name	Order Number	Order Number	Order Number	Order Number	Order Number	Order Number				
1/8"	1/8"	1-1/2"	1-1/2"	CK-1/8-W	02520	02540	02560	02580	02600	02620
3/16"	3/16"	1-1/2"	1-1/2"	CK-3/16-W	02521	02541	02561	02581	02601	02621
1/4"	3/16"	1-1/2"	3/4"	CK-1/4-W	02522	02542	02562	02582	02602	02622
5/16"	1/4"	2-1/4"	7/8"	CK-5/16-W	02523	02543	02563	02583	02603	02623
3/8"	1/4"	2-1/4"	7/8"	CK-3/8-W	02524	02544	02564	02584	02604	02624
1/2"	3/8"	2-1/4"	1-1/8"	CK-1/2-W	02525	02545	02565	02585	02605	02625
1/2"	1/4"	2-1/4"	1-1/8"	CK-1/2-W-1/4	02526	02546	02566	02586	02606	02626
5/8"	3/8"	2-3/8"	1-1/8"	CK-5/8-W	02527	02547	02567	02587	02607	02627
5/8"	1/4"	2-3/8"	1-1/8"	CK-5/8-W-1/4	02528	02548	02568	02588	02608	02628
3/4"	1/2"	2-11/16"	1-5/16"	CK-3/4-W	02529	02549	02569	02589	02609	02629
7/8"	1/2"	2-13/16"	1-5/16"	CK-7/8-W	02530	02550	02570	02590	02610	02630
1"	1/2"	2-13/16"	1-5/16"	CK-1-W	02531	02551	02571	02591	02611	02631
1-1/4"	3/4"	3-3/8"	1-5/8"	CK-1-1/4-W	02532	02552	02572	02592	02612	02632
1-1/2"	3/4"	3-1/2"	1-5/8"	CK-1-1/2-W	02533	02553	02573	02593	02613	02633
1-3/4"	1"	4-1/4"	2-1/8"	CK-1-3/4-W	02534	02554	02574	02594	02614	02634
2"	1"	4-3/8"	2-1/8"	CK-2-W	02535	02555	02575	02595	02615	02635



## The Original 6-Flute Double Ended Chatterless-Countersinks™

Reduces tooling investment, since one dual-ended countersink costs less than the alternative two single end tools. These tools feature our positive shear cutting edge and six staggered flutes to reduce chatter.

### High Speed Steel

Head Dia.	Overall Length	Centerline Angle		30°	41°	45°	50°	55°	60°
		Included Angle		60°	82°	90°	100°	110°	120°
		Severance Name	Order Number	Order Number	Order Number	Order Number	Order Number	Order Number	
1/8"	1-1/2"	CK-1/8-DE	02670	02685	02700	02715	02730	02745	
3/16"	1-7/8"	CK-3/16-DE	02671	02686	02701	02716	02731	02746	
1/4"	2"	CK-1/4-DE	02672	02687	02702	02717	02732	02747	
5/16"	2-1/8"	CK-5/16-DE	02673	02688	02703	02718	02733	02748	
3/8"	2-1/2"	CK-3/8-DE	02674	02689	02704	02719	02734	02749	
1/2"	3"	CK-1/2-DE	02675	02690	02705	02720	02735	02750	
5/8"	3-1/4"	CK-5/8-DE	02676	02691	02706	02721	02736	02751	
3/4"	3-1/2"	CK-3/4-DE	02677	02692	02707	02722	02737	02752	

### Carbide

Head Dia.	Overall Length	Centerline Angle		30°	41°	45°	50°	55°	60°
		Included Angle		60°	82°	90°	100°	110°	120°
		Severance Name	Order Number	Order Number	Order Number	Order Number	Order Number	Order Number	
1/8"	1-1/2"	CK-1/8-W-DE	02820	02835	02850	02865	02880	02895	
3/16"	2"	CK-3/16-W-DE	02821	02836	02851	02866	02881	02896	
1/4"	2"	CK-1/4-W-DE	02822	02837	02852	02867	02882	02897	
5/16"	2-1/8"	CK-5/16-W-DE	02823	02838	02853	02868	02883	02898	
3/8"	2-1/2"	CK-3/8-W-DE	02824	02839	02854	02869	02884	02899	
1/2"	3"	CK-1/2-W-DE	02825	02840	02855	02870	02885	02900	
5/8"	3-1/4"	CK-5/8-W-DE	02826	02841	02856	02871	02886	02901	
3/4"	3-1/2"	CK-3/4-W-DE	02827	02842	02857	02872	02887	02902	

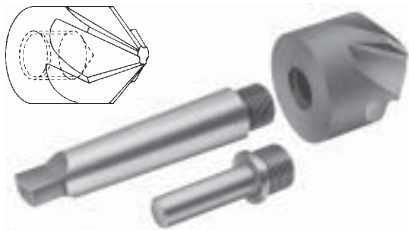

## The Original 6-Flute Threaded Chatterless-Countersinks™

These countersink have a threaded back for use with separately ordered shanks. Ideal for use on radial drills, lathes, and Mills.

### High Speed Steel

Head Dia.	Overall Length	Thread Size	Centerline Angle		30°	41°	45°	50°	55°	60°
			Included Angle		60°	82°	90°	100°	110°	120°
			Severance Name	Order Number	Order Number	Order Number	Order Number	Order Number	Order Number	
3/4"	1-1/2"	3/8"-24	CK-3/4-T	03270	03280	03290	03300	03310	03320	
7/8"	1-1/2"	3/8"-24	CK-7/8-T	03271	03281	03291	03301	03311	03321	
1"	1-1/2"	1/2"-20	CK-1-T	03272	03282	03292	03302	03312	03322	
1-1/4"	1-3/4"	5/8"-18	CK-1-1/4-T	03273	03283	03293	03303	03313	03323	
1-1/2"	1-7/8"	3/4"-16	CK-1-1/2-T	03274	03284	03294	03304	03314	03324	
1-3/4"	2-1/8"	3/4"-16	CK-1-3/4-T	03275	03285	03295	03305	03315	03325	
2"	2-1/4"	3/4"-16	CK-2-T	03276	03286	03296	03306	03316	03326	
2-1/2"	3"	1"-14	CK-2-1/2-T	03277	03287	03297	03307	03317	03327	
3"	3-1/4"	1-1/4"-12	CK-3-T	03278	03288	03298	03308	03318	03328	

See pages 78-80 for other available shank styles and sizes.



Style "F"



Style "N"

### 6-Flute Heavy Duty Chatterless - Countersinks™

For heavy-duty work in conjunction with the Glenzer sleeve on drill presses, lathes, screw-machines, etc. These countersinks are designed to take heavy cuts and at the same time produce a very smooth seat. These heavy-duty tools are available in two styles without flutes (style N) and with flutes (style F). Ideal for use in bushings, Other angles are available as specials.

#### High Speed Steel

Head Dia.	Shank Dia.	Overall Length	Shank Length	Centerline Angle			
				Included	30°	41°	45°
				60°	82°	90°	
				Severance Name	Order Number	Order Number	Order Number
3/8"	13/32"	2-13/16"	1-7/16"	HD-3/8-N	03920	03940	03960
3/8"	13/32"	2-13/16"	1-7/16"	HD-3/8-F	03921	03941	03961
1/2"	13/32"	3-1/16"	1-11/16"	HD-1/2-N	03922	03942	03962
1/2"	13/32"	3-1/16"	1-11/16"	HD-1/2-F	03923	03943	03963
3/4"	3/4"	3-7/8"	2-1/8"	HD-3/4-N	03924	03944	03964
3/4"	3/4"	3-7/8"	2-1/8"	HD-3/4-F	03925	03945	03965
1"	3/4"	4-5/16"	1-3/4"	HD-1-N	03926	03946	03966
1"	3/4"	4-5/16"	1-3/4"	HD-1-F	03927	03947	03967
1-1/4"	1"	5"	2-1/4"	HD-1-1/4-N	03928	03948	03968
1-1/4"	1"	5"	2-1/4"	HD-1-1/4-F	03929	03949	03969
1-1/2"	1"	5-1/4"	2-1/4"	HD-1-1/2-N	03930	03950	03970
1-1/2"	1"	5-1/4"	2-1/4"	HD-1-1/2-F	03931	03951	03971
2"	1"	5-3/4"	2-1/4"	HD-2-N	03932	03952	03972
2"	1"	5-3/4"	2-1/4"	HD-2-F	03933	03953	03973



#### Steel



O.D. Taper	Fits Shank Diameter	Glenzer NO.	EDP Order Number
2 M.T.	13/32"	778932	36210
3 M.T.	3/4"	778954	36211
4 M.T.	1"	778970	36212

### Glenzer Sleeve

To be used with Severance Heavy Duty Countersinks above and straight tanged shanks seen on page 76.



### 6-Flute Chatterless - Countersinks™ for Wheels

Severance developed the Chatterless™ Wheel Countersinks for use in the wheel manufacturing industry. Available in Heavy Duty style F and N, and our standard style tools. Our tools have been used on Semi truck and trailer wheels. For use on off the road wheels, heavy equipment wheels, car and truck wheels, custom wheels, break drums, wheel components, hubs, trailer wheels, and motorcycle wheels to produce a smooth seat and angle for the lug nuts. Custom designed for each specific application, diameter, angle, form and radius in High Speed Steel, Carbide, or Coated.



### CNC-K™ Precision Chatterless-Countersinks™

Designed for use in NC, CNC, Vertical and Horizontal, also CNC Lathes, and Multi Axis machines. These Precision countersinks feature our 6 flute Chatterless™ tooth geometry. Tighter tolerances on angles, diameters, and lengths assure setting accuracy. See page 87 for programming and setup assistance.

See Page 87 for programming and setup assistance

#### High Speed Steel

BODY DIA.	NOSE DIA. +.001-.000	SHANK DIA.	OVERALL LENGTH	SHANK LENGTH	CENTERLINE ANGLE							
					INCLUDED ANGLE		30°	41°	45°	50°	55°	60°
					SEVERANCE NAME	ORDER NUMBER	ORDER NUMBER	ORDER NUMBER	ORDER NUMBER	ORDER NUMBER	ORDER NUMBER	
1/4"	.078	3/16"	1-1/2"	3/4"	CNC-K-1/4	02970	-	-	-	-	-	-
1/4"	.046	3/16"	1-1/2"	3/4"	CNC-K-1/4	-	02980	02990	03000	03010	03020	-
3/8"	.125	1/4"	1-3/4"	7/8"	CNC-K-3/8	02971	-	-	-	-	-	-
3/8"	.078	1/4"	1-3/4"	7/8"	CNC-K-3/8	-	02981	02991	03001	-	-	-
3/8"	.062	1/4"	1-3/4"	7/8"	CNC-K-3/8	-	-	-	-	03011	03021	-
1/2"	.156	3/8"	2-1/8"	1-1/8"	CNC-K-1/2	02972	-	-	-	-	-	-
1/2"	.109	3/8"	2-1/8"	1-1/8"	CNC-K-1/2	-	02982	02992	03002	-	-	-
1/2"	.078	3/8"	2-1/8"	1-1/8"	CNC-K-1/2	-	-	-	-	03012	03022	-
5/8"	.203	3/8"	2-3/8"	1-1/8"	CNC-K-5/8	02973	-	-	-	-	-	-
5/8"	.125	3/8"	2-3/8"	1-1/8"	CNC-K-5/8	-	02983	02993	03003	-	-	-
5/8"	.109	3/8"	2-3/8"	1-1/8"	CNC-K-5/8	-	-	-	-	03013	03023	-
3/4"	.250	1/2"	2-11/16"	1-5/16"	CNC-K-3/4	02974	-	-	-	-	-	-
3/4"	.156	1/2"	2-11/16"	1-5/16"	CNC-K-3/4	-	02984	02994	03004	-	-	-
3/4"	.125	1/2"	2-11/16"	1-5/16"	CNC-K-3/4	-	-	-	-	03014	03024	-
7/8"	.281	1/2"	2-13/16"	1-5/16"	CNC-K-7/8	02975	-	-	-	-	-	-
7/8"	.172	1/2"	2-13/16"	1-5/16"	CNC-K-7/8	-	02985	02995	03005	-	-	-
7/8"	.140	1/2"	2-13/16"	1-5/16"	CNC-K-7/8	-	-	-	-	03015	03025	-
1"	.328	1/2"	2-13/16"	1-5/16"	CNC-K-1	02976	-	-	-	-	-	-
1"	.203	1/2"	2-13/16"	1-5/16"	CNC-K-1	-	02986	02996	03006	-	-	-
1"	.171	1/2"	2-13/16"	1-5/16"	CNC-K-1	-	-	-	-	03016	03026	-



### CNC-K™ Precision Double Ended Countersinks

These precision countersinks have our 6-Flute chatterless™ design. Double-Ended Countersinks can help reduce manufacturing costs by lowering tool inventories and labor costs. When one end of the countersink dulls, simply reverse the tool and continue machining operations.

See Page 87 for programming and setup assistance

#### High Speed Steel

Head Dia.	Overall Length	Nose Dia.	Centerline Angle							
			Included Angle		30°	41°	45°	50°	55°	60°
			Severance Name	Order Number	Order Number	Order Number	Order Number	Order Number	Order Number	
1/8"	1-1/2"	See single ended above for nose flats	CNC-K-1/8-DE	03177	03185	03193	03201	03209	03217	
3/16"	1-7/8"		CNC-K-3/16-DE	03178	03186	03194	03202	03210	03218	
1/4"	2"		CNC-K-1/4-DE	03179	03187	03195	03203	03211	03219	
5/16"	2-1/8"		CNC-K-5/16-DE	03180	03188	03196	03204	03212	03220	
3/8"	2-1/2"		CNC-K-3/8-DE	03181	03189	03197	03205	03213	03221	
1/2"	3"		CNC-K-1/2-DE	03182	03190	03198	03206	03214	03222	
5/8"	3 -1/4"		CNC-K-5/8-DE	03183	03191	03199	03207	03215	03223	
3/4"	3 -1/2"		CNC-K-3/4-DE	03184	03192	03200	03208	03216	03224	



See Page 87 for programming and setup assistance

## CNC-K™ Precision Chatterless-Countersinks™

Designed for use in NC, CNC, Vertical and Horizontal, also CNC Lathes, and Multi Axis machines. These Precision countersinks feature our 6 flute Chatterless™ tooth geometry. Tighter tolerances on angles, diameters, and lengths assure setting accuracy. See page 87 for programming and setup assistance.

### Carbide

BODY DIA.	NOSE DIA. +.001-.000	SHANK DIA.	OVERALL LENGTH	SHANK LENGTH	CENTERLINE ANGLE INCLUDED ANGLE	30°	41°	45°	50°	55°	60°
					SEVERANCE NAME	60°	82°	90°	100°	110°	120°
						ORDER NUMBER	ORDER NUMBER	ORDER NUMBER	ORDER NUMBER	ORDER NUMBER	ORDER NUMBER
1/4"	.078	3/16"	1-1/2"	3/4"	CNC-K-1/4-W	03120	-	-	-	-	-
1/4"	.046	3/16"	1-1/2"	3/4"	CNC-K-1/4-W	-	03130	03140	03150	03160	03170
3/8"	.125	1/4"	1-3/4"	7/8"	CNC-K-3/8-W	03121	-	-	-	-	-
3/8"	.078	1/4"	1-3/4"	7/8"	CNC-K-3/8-W	-	03131	03141	03151	-	-
3/8"	.062	1/4"	1-3/4"	7/8"	CNC-K-3/8-W	-	-	-	-	03161	03171
1/2"	.156	3/8"	2-1/4"	1-1/8"	CNC-K-1/2-W	03122	-	-	-	-	-
1/2"	.109	3/8"	2-1/4"	1-1/8"	CNC-K-1/2-W	-	03132	03142	03152	-	-
1/2"	.078	3/8"	2-1/4"	1-1/8"	CNC-K-1/2-W	-	-	-	-	03162	03172
5/8"	.203	3/8"	2-3/8"	1-1/8"	CNC-K-5/8-W	03123	-	-	-	-	-
5/8"	.125	3/8"	2-3/8"	1-1/8"	CNC-K-5/8-W	-	03133	03143	03153	-	-
5/8"	.109	3/8"	2-3/8"	1-1/8"	CNC-K-5/8-W	-	-	-	-	03163	03173
3/4"	.250	1/2"	2-11/16"	1-5/16"	CNC-K-3/4-W	03124	-	-	-	-	-
3/4"	.156	1/2"	2-11/16"	1-5/16"	CNC-K-3/4-W	-	03134	03144	03154	-	-
3/4"	.125	1/2"	2-11/16"	1-5/16"	CNC-K-3/4-W	-	-	-	-	03164	03174
7/8"	.281	1/2"	2-13/16"	1-5/16"	CNC-K-7/8-W	03125	-	-	-	-	-
7/8"	.172	1/2"	2-13/16"	1-5/16"	CNC-K-7/8-W	-	03135	03145	03155	-	-
7/8"	.140	1/2"	2-13/16"	1-5/16"	CNC-K-7/8-W	-	-	-	-	03165	03175
1"	.328	1/2"	2-13/16"	1-5/16"	CNC-K-1-W	03126	-	-	-	-	-
1"	.203	1/2"	2-13/16"	1-5/16"	CNC-K-1-W	-	03136	03146	03156	-	-
1"	.171	1/2"	2-13/16"	1-5/16"	CNC-K-1-W	-	-	-	-	03166	03176



See Page 87 for programming and setup assistance

## CNC-K™ Precision Double Ended Countersinks

These precision countersinks have our 6-Flute Chatterless™ design. Double-Ended Countersinks can help reduce manufacturing costs by lowering tool inventories and labor costs. When one end of the countersink dulls, simply reverse the tool and continue machining operations.

### Carbide

Head Dia.	Overall Length	Nose Dia.	Centerline Angle		30°	41°	45°	50°	55°	60°
			Included Angle	60°	82°	90°	100°	110°	120°	
			Severance Name	Order Number	Order Number	Order Number	Order Number	Order Number	Order Number	Order Number
1/8"	1-1/2"	See single ended above for nose flats	CNC-K-1/8-W-DE	03423	03431	03439	03447	03455	03463	
3/16"	1-7/8"		CNC-K-3/16-W-DE	03424	03432	03440	03448	03456	03464	
1/4"	2"		CNC-K-1/4-W-DE	03425	03433	03441	03449	03457	03465	
5/16"	2-1/8"		CNC-K-5/16-W-DE	03426	03434	03442	03450	03458	03466	
3/8"	2-1/2"		CNC-K-3/8-W-DE	03427	03435	03443	03451	03459	03467	
1/2"	3"		CNC-K-1/2-W-DE	03428	03436	03444	03452	03460	03468	
5/8"	3-1/4"		CNC-K-5/8-W-DE	03429	03437	03445	03453	03461	03469	
3/4"	3-1/2"		CNC-K-3/4-W-DE	03430	03438	03446	03454	03462	03470	

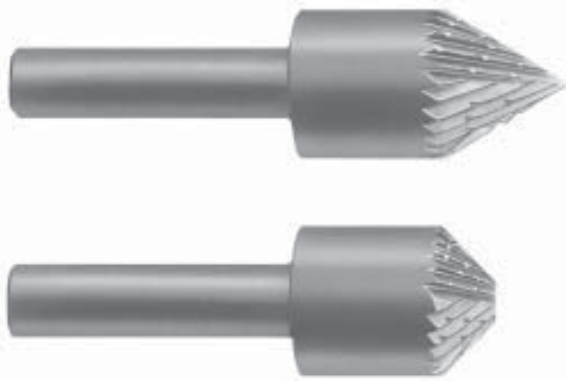

## Multi-Flute Countersinks

Teeth as regularly furnished on these cutters are for quick light chamfering only. Stocked in 30° C/L and 45° C/L. The Inside Deburring Cutter is designed so that one tool can deburr many different hole diameters. The multi-flute design is self-piloting. For heavier countersinking, special arbors, or special angles, submit details to our Engineering Department.

### High Speed Steel

30° C/L (60° Included) Solid

Head Dia.	Nose Point or Flat Dia.	Overall Length	Severance Tool Name	EDP Order Number
1/4"	P	2-1/4"	ID-1/4-30	20770
5/16"	1/32"	2-1/4"	ID-5/16-30	20771
3/8"	P	2-1/4"	ID-3/8-30	20772
1/2"	9/64"	2-1/4"	IDS-1/2-30	20773
1/2"	P	2-1/4"	IDL-1/2-30	20774
5/8"	13/64"	2-1/4"	IDS-5/8-30	20775

### High Speed Steel

45° C/L (90° Included) Solid

Head Dia.	Nose Point or Flat Dia.	Overall Length	Severance Tool Name	EDP Order Number
1/4"	P	2-1/4"	ID-1/4-45	20805
5/16"	1/16"	2-1/4"	ID-5/16-45	20806
3/8"	P	2-1/4"	ID-3/8-45	20807
1/2"	1/8"	2-1/4"	IDS-1/2-45	20808
1/2"	P	2-1/4"	IDL-1/2-45	20809
5/8"	1/8"	2-1/4"	IDS-5/8-45	20810



Tools are furnished without shanks.  
See pages 78-80 for available shank styles and sizes.

### High Speed Steel

30° C/L (60° Included) Threaded

Head Dia.	Nose Point or Flat Dia.	Overall Length	Thread Size	Severance Tool Name	EDP Order Number
5/8"	3/64"	7/8"	1/4"-28	ID-5/8-30	20776
3/4"	1/32"	1"	5/16"-24	ID-3/4-30	20777
7/8"	5/32"	1"	3/8"-24	ID-7/8-30	20778
1"	9/32"	1-1/8"	3/8"-24	IDS-1-30	20779
1"	1/8"	1-1/8"	3/8"-24	IDL-1-30	20780
1-1/8"	1/8"	1-1/8"	3/8"-24	ID-1-1/8-30	20781
1-1/4"	17/32"	1"	3/8"-24	IDS-1-1/4-30	20782
1-1/4"	3/32"	1-1/4"	3/8"-24	IDL-1-1/4-30	20783
1-1/2"	31/64"	1-1/8"	1/2"-20	IDS-1-1/2-30	20784
1-1/2"	13/64"	1-1/2"	1/2"-20	IDL-1-1/2-30	20785
1-3/4"	3/4"	1-1/4"	1/2"-20	IDS-1-3/4-30	20786
1-3/4"	5/16"	1-1/2"	1/2"-20	IDL-1-3/4-30	20787
2"	63/64"	1-1/4"	5/8"-18	IDS-2-30	20788
2"	27/32"	1-1/4"	5/8"-18	IDL-2-30	20789
2-1/4"	1-3/32"	1-3/8"	3/4"-16	IDS-2-1/4-30	20790
2-1/4"	33/64"	1-7/8"	3/4"-16	IDL-2-1/4-30	20791
2-1/2"	1-31/64"	1-1/4"	3/4"-16	IDS-2-1/2-30	20792
2-1/2"	29/32"	1-3/4"	3/4"-16	IDL-2-1/2-30	20793
3"	1-63/64"	1-1/4"	1"-14	ID-3-30	20794

### High Speed Steel

45° C/L (90° Included) Threaded

Head Dia.	Nose Point or Flat Dia.	Overall Length	Thread Size	Severance Tool Name	EDP Order Number
5/8"	1/8"	11/16"	1/4"-28	ID-5/8-45	20811
3/4"	P	13/16"	5/16"-24	ID-3/4-45	20812
7/8"	5/32"	1"	3/8"-24	ID-7/8-45	20813
1"	1/4"	7/8"	3/8"-24	IDS-1-45	20814
1"	P	7/8"	3/8"-24	IDL-1-45	20815
1-1/4"	3/8"	3/4"	3/8"-24	IDS-1-1/4-45	20816
1-1/4"	P	1"	3/8"-24	IDL-1-1/4-45	20817
1-1/2"	1/2"	7/8"	1/2"-20	IDS-1-1/2-45	20818
1-1/2"	1/4"	1-1/16"	1/2"-20	IDL-1-1/2-45	20819
1-3/4"	5/8"	7/8"	1/2"-20	ID-1-3/4-45	20820
2"	1"	1"	5/8"-18	IDS-2-45	20821
2"	1/4"	1-1/2"	5/8"-18	IDL-2-45	20822
2-1/4"	1"	1"	5/8"-18	IDS-2-1/4-45	20823
2-1/4"	1/4"	1-3/8"	5/8"-18	IDL-2-1/4-45	20824
2-1/2"	3/4"	1-3/8"	3/4"-16	IDS-2-12-45	20825
2-1/2"	1/4"	1-5/8"	3/4"-16	IDL-2-1/2-45	20826
3"	3/4"	1-3/4"	1"-14	IDS-3-45	20827
3"	1/4"	1-7/8"	1"-14	IDL-3-45	20828



## Multi-Flute Countersinks

All carbide Inside Deburring Cutters are designed with a pointed nose. Tools with a head diameter measuring 3/32" thru 1/4" are made of solid carbide and are double ended. Inside Deburring Cutters with a head diameter measuring 5/16" thru 1" have solid carbide heads brazed to hardened alloy precision ground shanks.

### Carbide

30° C/L (60° Included)

### Carbide

45° C/L (90° Included)

Head Dia.	Shank Dia.	Overall Length
3/32"	3/32"	1-1/2"
1/8"	1/8"	1-1/2"
3/16"	3/16"	2"
1/4"	1/4"	2"
5/16"	1/4"	2-1/4"
3/8"	1/4"	2-1/4"
1/2"	1/4"	2-1/4"
1/2"	3/8"	2-1/8"
5/8"	1/4"	2-3/8"
5/8"	3/8"	2-3/8"
3/4"	1/2"	2-11/16"
7/8"	1/2"	2-13/16"
1"	1/2"	2-13/16"

Severance Tool Name	EDP Order Number
3Z-W-DE	20620
4Z-W-DE	22250
6Z-W-DE	20622
8Z-W-DE	22411
ID-5/16-30-W	20628
ID-3/8-30-W	20629
ID-1/2-30-W	20633
ID-1/2-30-W-3/8	20634
ID-5/8-30-W	20639
ID-5/8-30-W-3/8	20640
ID-3/4-30-W	20644
ID-7/8-30-W	20649
ID-1-30-W	20650

Severance Tool Name	EDP Order Number
3Y-W-DE	20680
4Y-W-DE	22249
6Y-W-DE	20682
8Y-W-DE	22412
ID-5/16-45-W	20688
ID-3/8-45-W	20689
ID-1/2-45-W	20693
ID-1/2-45-W-3/8	20694
ID-5/8-45-W	20699
ID-5/8-45-W-3/8	20700
ID-3/4-45-W	20704
ID-7/8-45-W	20709
ID-1-45-W	20710



## Multi-Flute Countersinks

Severance Inside Chamfering Mills can be depended upon to produce smooth, burrless, chamfers on most machinable materials and are suitable for fairly heavy chamfering. For still heavier chamfering, consider Severance's Chatterless™ countersinks.

### High Speed Steel

30° C/L (60° Included) Solid

Head Dia.	Nose Point or Flat Dia.	Overall Length	Severance Tool Name	EDP Order Number
1/4"	P	2-1/4"	IC-1/4-30	20470
5/16"	1/32"	2-1/4"	IC-5/16-30	20471
3/8"	P	2-1/4"	IC-3/8-30	20472
1/2"	9/64"	2-1/4"	ICS-1/2-30	20473
1/2"	P	2-1/4"	ICL-1/2-30	20474
5/8"	13/64"	2-1/4"	ICS-5/8-30	20475

### High Speed Steel

45° C/L (90° Included) Solid

Head Dia.	Nose Point or Flat Dia.	Overall Length	Severance Tool Name	EDP Order Number
1/4"	P	2-1/4"	IC-1/4-45	20505
5/16"	1/16"	2-1/4"	IC-5/16-45	20506
3/8"	P	2-1/4"	IC-3/8-45	20507
1/2"	1/8"	2-1/4"	ICS-1/2-45	20508
1/2"	P	2-1/4"	ICL-1/2-45	20509
5/8"	1/8"	2-1/4"	ICS-5/8-45	20510

## Miniature Multi-Flute Countersinks

### 3/32" Shank Diameter – 1-5/8"

Used on small hole and parts to chamfer or break the edge. May be resharpened many times. 3/32" shanks 25° C/L angle.



Head Dia.	Flute Length	Severance Tool Name	EDP Order Number
-----------	--------------	---------------------	------------------

### Cone, Pointed Nose, 25° C/L Angle

1/16"	.081"	LM2-062	22626
3/32"	.122"	LM2-093	22627
1/8"	.162"	LM2-125	22628
3/16"	.244"	LM2-187	22629
1/4"	.325"	LM2-250	22630
5/16"	.407"	LM2-312	22631

Multi-Flute Countersinks Continued...

Tools are furnished without shanks.  
See pages 78-80 for available shank styles and sizes.

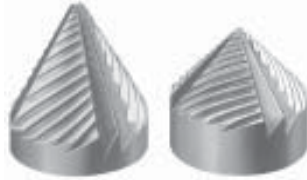

**High Speed Steel**

30° C/L (60° Included) Threaded

Head Dia.	Nose Point or Flat Dia.	Overall Length	Thread Size	Severance Tool Name	EDP Order Number
5/8"	3/64"	7/8"	1/4"-28	IC-5/8-30	20476
3/4"	1/32"	1"	5/16"-24	IC-3/4-30	20477
7/8"	5/32"	1"	3/8"-24	IC-7/8-30	20478
1"	9/32"	1-1/8"	3/8"-24	ICS-1-30	20479
1"	1/8"	1-1/8"	3/8"-24	ICL-1-30	20480
1-1/8"	1/8"	1-1/8"	3/8"-24	IC-1-1/8-30	20481
1-1/4"	17/32"	1"	3/8"-24	ICS-1-1/4-30	20482
1-1/4"	3/32"	1-1/4"	3/8"-24	ICL-1-1/4-30	20483
1-1/2"	31/64"	1-1/8"	1/2"-20	ICS-1-1/2-30	20484
1-1/2"	13/64"	1-1/2"	1/2"-20	ICL-1-1/2-30	20485
1-3/4"	3/4"	1-1/4"	1/2"-20	ICS-1-3/4-30	20486
1-3/4"	5/16"	1-1/2"	1/2"-20	ICL-1-3/4-30	20487
2"	63/64"	1-1/4"	5/8"-18	ICS-2-30	20488
2"	27/32"	1-1/4"	5/8"-18	ICL-2-30	20489
2-1/4"	1-3/32"	1-3/8"	3/4"-16	ICS-2-1/4-30	20490
2-1/4"	33/64"	1-7/8"	3/4"-16	ICL-2-1/4-30	20491
2-1/2"	1-31/64"	1-1/4"	3/4"-16	ICS-2-1/2-30	20492
2-1/2"	29/32"	1-3/4"	3/4"-16	ICL-2-1/2-30	20493
3"	1-63/64"	1-1/4"	1"-14	IC-3-30	20494

**High Speed Steel**

45° C/L (90° Included) Threaded

Head Dia.	Nose Point or Flat Dia.	Overall Length	Thread Size	Severance Tool Name	EDP Order Number
5/8"	1/8"	11/16"	1/4"-28	IC-5/8-45	20511
3/4"	P	13/16"	5/16"-24	IC-3/4-45	20512
7/8"	5/32"	1"	3/8"-24	IC-7/8-45	20513
1"	1/4"	7/8"	3/8"-24	ICS-1-45	20514
1"	P	7/8"	3/8"-24	ICL-1-45	20515
1-1/4"	3/8"	3/4"	3/8"-24	ICS-1-1/4-45	20516
1-1/4"	P	1"	3/8"-24	ICL-1-1/4-45	20517
1-1/2"	1/2"	7/8"	1/2"-20	ICS-1-1/2-45	20518
1-1/2"	1/4"	1-1/16"	1/2"-20	ICL-1-1/2-45	20519
1-3/4"	5/8"	7/8"	1/2"-20	IC-1-3/4-45	20520
2"	1"	1"	5/8"-18	ICS-2-45	20521
2"	1/4"	1-1/2"	5/8"-18	ICL-2-45	20522
2-1/4"	1"	1"	5/8"-18	ICS-2-1/4-45	20523
2-1/4"	1/4"	1-3/8"	5/8"-18	ICL-2-1/4-45	20524
2-1/2"	3/4"	1-3/8"	3/4"-16	ICS-2-1/2-45	20525
2-1/2"	1/4"	1-5/8"	3/4"-16	ICL-2-1/2-45	20526
3"	3/4"	1-3/4"	1"-14	ICS-3-45	20527
3"	1/4"	1-7/8"	1"-14	ICL-3-45	20528



**3N1® Drill Point Double Ended Countersinks**

We have developed a unique tool, which combines the functions of a drill point, countersink, and edge chamfer. One double ended countersink is less costly than two single ended tools.

**High Speed Steel**

Head Dia.	Overall Length	Drill Point Dia.	Centerline Angle											
			30°		41°		45°		50°		55°		60°	
			Included Angle		82°		90°		100°		110°		120°	
			Severance Name	Order Number	Order Number	Order Number	Order Number	Order Number	Order Number	Order Number	Order Number	Order Number		
1/8"	1-1/2"	.047"	3N1-1/8-DE	01585	01595	01605	01615	01625	01635					
3/16"	1-7/8"	.078"	3N1-3/16-DE	01586	01596	01606	01616	01626	01636					
1/4"	2"	.109"	3N1-1/4-DE	01587	01597	01607	01617	01627	01637					
5/16"	2-1/8"	.125"	3N1-5/16-DE	01588	01598	01608	01618	01628	01638					
3/8"	2-1/2"	.141"	3N1-3/8-DE	01589	01599	01609	01619	01629	01639					
1/2"	3"	.219"	3N1-1/2-DE	01590	01600	01610	01620	01630	01640					
5/8"	3-1/4"	.25"	3N1-5/8-DE	01591	01601	01611	01621	01631	01641					
3/4"	3-1/2"	.313"	3N1-3/4-DE	01592	01602	01612	01622	01632	01642					

**Carbide**

Head Dia.	Overall Length	Drill Point Dia.	Centerline Angle											
			30°		41°		45°		50°		55°		60°	
			Included Angle		82°		90°		100°		110°		120°	
			Severance Name	Order Number	Order Number	Order Number	Order Number	Order Number	Order Number	Order Number	Order Number			
1/8"	1-1/2"	.047"	3N1-1/8-W-DE	01650	01670	01680	01690	01700	01710					
3/16"	2"	.078"	3N1-3/16-W-DE	01651	01671	01681	01691	01701	01711					
1/4"	2"	.109"	3N1-1/4-W-DE	01652	01672	01682	01692	01702	01712					
5/16"	2-1/8"	.125"	3N1-5/16-W-DE	01653	01673	01683	01693	01703	01713					
3/8"	2-1/2"	.141"	3N1-3/8-W-DE	01654	01674	01684	01694	01704	01714					
1/2"	3"	.219"	3N1-1/2-W-DE	01655	01675	01685	01695	01705	01715					
5/8"	3-1/4"	.25"	3N1-5/8-W-DE	01656	01676	01686	01696	01706	01716					
3/4"	3-1/2"	.313"	3N1-3/4-W-DE	01657	01677	01687	01697	01707	01717					

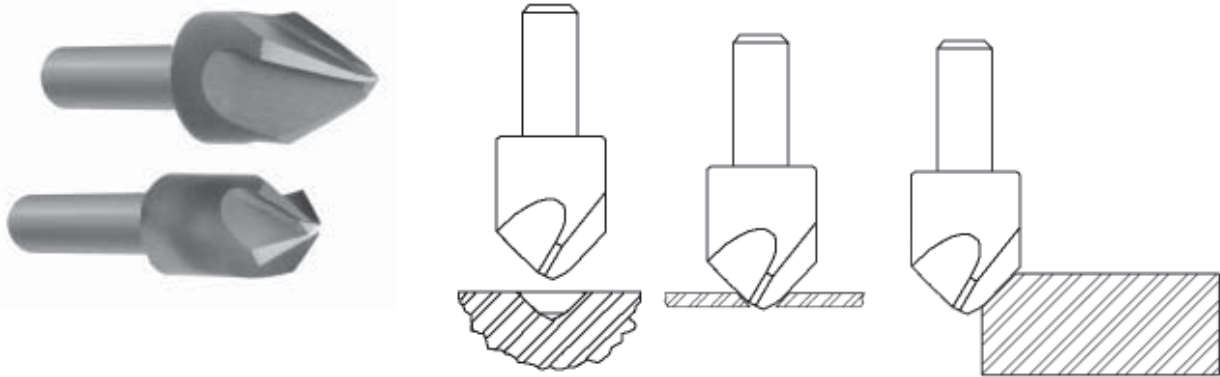

### 3N1® Drill Point Countersinks

We have developed a unique tool, which combines the functions of a **drill point** and **countersink** and **edge chamfer**. A conventional thin-web drill point is blended into two flutes of a four-flute chatter-free™ countersink ... to perform two or all three of the steps in a spot-drill-countersink and edge chamfer operations. Save steps, setup, production time, and lower scrap rates with a Severance 3N1® spotting tool. Specifically designed to give a true start spot and an accurate countersink chamfer on your part. See 3N1® Double Ended Countersinks on page 57.

#### High Speed Steel

Head Dia.	Shank Dia.	Overall Length	Shank Length	Centerline Angle						
				30°	41°	45°	50°	55°	60°	
				Included Angle 60°	82°	90°	100°	110°	120°	
Severance Name	Order Number	Order Number	Order Number	Order Number	Order Number	Order Number				
1/8"	1/8"	1-5/8"	1-5/8"	3N1-1/8	01473	01488	01503	01518	01533	01548
3/16"	3/16"	1-1/2"	1-1/2"	3N1-3/16	01474	01489	01504	01519	01534	01549
1/4"	3/16"	1-1/2"	3/4"	3N1-1/4	01470	01485	01500	01515	01530	01545
1/4"	1/4"	2"	1-3/4"	3N1-1/4-1/4	01464	01465	01466	01467	01468	01469
5/16"	1/4"	1-3/4"	7/8"	3N1-5/16	01475	01490	01505	01520	01535	01550
3/8"	1/4"	1-3/4"	7/8"	3N1-3/8	01471	01486	01501	01516	01531	01546
1/2"	3/8"	2-1/8"	1-1/8"	3N1-1/2	01472	01487	01502	01517	01532	01547
5/8"	3/8"	2-3/8"	1-1/8"	3N1-5/8	01476	01491	01506	01521	01536	01551
3/4"	1/2"	2-11/16"	1-5/16"	3N1-3/4	01477	01492	01507	01522	01537	01552
7/8"	1/2"	2-13/16"	1-5/16"	3N1-7/8	01478	01493	01508	01523	01538	01553
1"	1/2"	2-13/16"	1-5/16"	3N1-1	01479	01494	01509	01524	01539	01554

#### Carbide

Head Dia.	Shank Dia.	Overall Length	Shank Length	Centerline Angle						
				30°	41°	45°	50°	55°	60°	
				Severance Name	Order Number	Order Number	Order Number	Order Number	Order Number	
1/8"	1/8"	1-5/8"	1-5/8"	3N1-1/8-W	01903	01923	01943	01963	01983	02003
3/16"	3/16"	1-1/2"	1-1/2"	3N1-3/16-W	01904	01924	01944	01964	01984	02004
1/4"	3/16"	1-1/2"	3/4"	3N1-1/4 -W	01905	01925	01945	01965	01985	02005
1/4"	1/4"	2"	1-3/4"	3N1-1/4-W-1/4	01906	01926	01946	01966	01986	02006
5/16"	1/4"	1-3/4"	7/8"	3N1-5/16-W	01907	01927	01947	01967	01987	02007
3/8"	1/4"	1-3/4"	7/8"	3N1-3/8-W	01908	01928	01948	01968	01988	02008
1/2"	3/8"	2-1/8"	1-1/8"	3N1-1/2 -W	01909	01929	01949	01969	01989	02009
5/8"	3/8"	2-3/8"	1-1/8"	3N1-5/8-W	01910	01930	01950	01970	01990	02010
3/4"	1/2"	2-11/16"	1-5/16"	3N1-3/4-W	01911	01931	01951	01971	01991	02011
7/8"	1/2"	2-13/16"	1-5/16"	3N1-7/8-W	01912	01932	01952	01972	01992	02012
1"	1/2"	2-13/16"	1-5/16"	3N1-1 -W	01913	01933	01953	01973	01993	02013

# 3N1-QC™ Quick Change Countersink System

Patent Pending

## Benefits of a 3N1-QC™ Drill Point Countersink

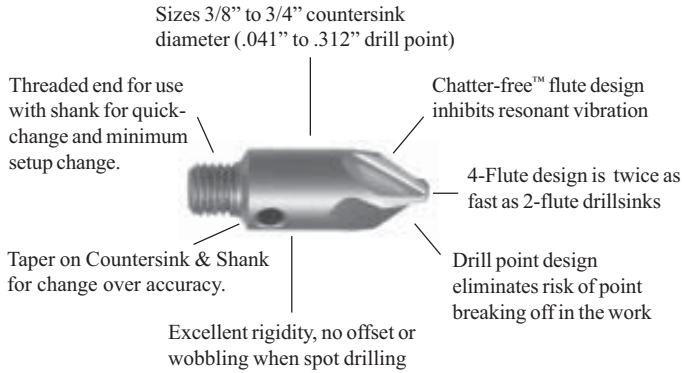

Save steps, setup, production time, and lower scrap rates with a Severance 3N1-QC™ Spotting tool. Specifically designed to give a true start spot and an accurate countersink chamfer on your part.

## Quick Change Countersink System

Severance Tool introduces the new 3N1-QC™ Quick Change Countersink System. Featuring standard shanks in 4", 6", and 8" over all lengths, this system is designed to allow quick change of the countersink head for fast tool changes while maintaining dimensional integrity. The quick-change head has a positive lock up on a 60° seat angle and with a threaded lock, tool changes are fast and simple. All 3N1-QC™ threaded countersinks are factory resharpenable.

### High Speed Steel

Head Dia.	Overall Length	Drill Point Dia.	Thread Size	Centerline Angle					
				30°	41°	45°	50°	60°	
				Included Angle 60°	82°	90°	100°	120°	
Severance Name	Order Number	Order Number	Order Number	Order Number	Order Number				
3/8"	1-5/32"	.141"	1/4"-28	3N1-QC-3/8	01800	01810	01820	01830	01840
7/16"	1-5/32"	.188"	1/4"-28	3N1-QC-7/16	01801	01811	01821	01831	01841
1/2"	1-5/32"	.219"	1/4"-28	3N1-QC-1/2	01802	01812	01822	01832	01842
5/8"	1-5/32"	.25"	1/4"-28	3N1-QC-5/8	01803	01813	01823	01833	01843
3/4"	1-13/16"	.313"	3/8"-24	3N1-QC-3/4	01804	01814	01824	01834	01844

Note: When Ordering 3N1-QC™ Make Sure To Specify Angle, Example (3N1-QC-3/8-45)

## Shanks for 3N1-QC™ Cutters



Thread Size	Shank		Overall Length	Shoulder Dia.	Severance Shank Name	EDP Order Number
	Frac.	Dia. Dec.				
1/4"-28	1/4"	.250	4"	7/16"	FM-2 Shank	34235
1/4"-28	1/2"	.500	6"	1/2"	FM-2x6 Shank	34239
1/4"-28	1/2"	.500	8"	1/2"	FM-2x8 Shank	34240
3/8"-24	1/4"	.250	4"	9/16"	FM-3 Shank	34236
3/8"-24	5/8"	.625	6"	5/8"	FM-3x6 Shank	34241
3/8"-24	5/8"	.625	8"	5/8"	FM-3x8 Shank	34242

See pages 78-80 for other available shank styles and sizes.

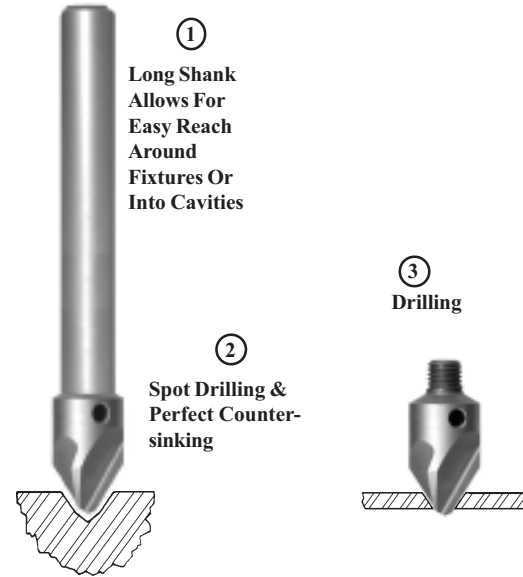

## How Does a 3N1-QC™ Work?

Severance has developed a unique tool, which combines the functions of a drill point starter and true countersink in a quick-change tool. A conventional thin-web drill point is blended into two flutes of a four-flute chatter-free™ countersink ... to perform two or all three of the steps in a spot-drill-countersink and edge chamfer operations. Once you have established a tool in a chuck, you can leave the shank in place and quickly change out the dull 3N1® head with a sharp 3N1®, fast change over. On thin material, such as above, drilling could be optional.

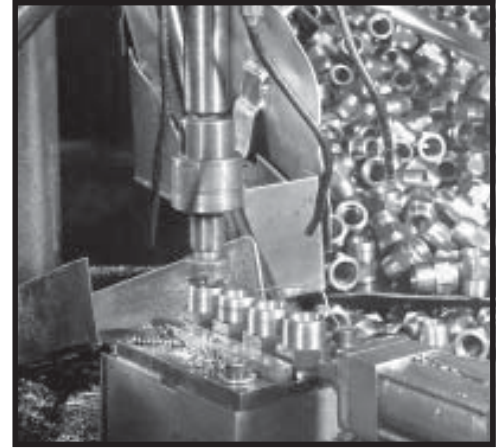

### 4-Flute Chatter-Free® Econo-Sinks®

Severance Econo-Sinks® features a Chatter-Free®, four-flute design. Econo-Sinks® are designed with four staggered cutting teeth arranged to insure free chip flow and rapid Chatter-Free® cutting. You will find the Econo-Sinks® give you better finishes, higher production, and more economic value than a single flute tool. Ideal on a wide range of materials including non-ferrous and other stringy materials and cast iron. Other diameters and angles available upon

#### Request High Speed Steel

Head Dia.	Shank Dia.	Overall Length	Shank Length	Centerline Angle											
				30°		41°		45°		50°		55°		60°	
				Included Angle		60°		82°		90°		100°		110°	
				Severance Name	Order Number	Order Number	Order Number	Order Number	Order Number	Order Number	Order Number	Order Number	Order Number		
1/8"	1/8"	1-5/8"	1-5/8"	ES-1/8	00970	00991	01012	01033	01054	01075					
3/16"	3/16"	1-1/2"	1-1/2"	ES-3/16	00971	00992	01013	01034	01055	01076					
1/4"	3/16"	1-1/2"	3/4"	ES-1/4	00972	00993	01014	01035	01056	01077					
5/16"	1/4"	1-3/4"	7/8"	ES-5/16	00973	00994	01015	01036	01057	01078					
3/8"	1/4"	1-3/4"	7/8"	ES-3/8	00974	00995	01016	01037	01058	01079					
1/2"	3/8"	2-1/8"	1-1/8"	ES-1/2	00976	00997	01018	01039	01060	01081					
1/2"	1/4"	2-1/8"	1-1/8"	ES-1/2-1/4	00977	00998	01019	01040	01061	01082					
5/8"	3/8"	2-3/8"	1-1/8"	ES-5/8	00978	00999	01020	01041	01062	01083					
5/8"	1/4"	2-3/8"	1-1/8"	ES-5/8-1/4	00979	01000	01021	01042	01063	01084					
3/4"	1/2"	2-11/16"	1-5/16"	ES-3/4	00980	01001	01022	01043	01064	01085					
7/8"	1/2"	2-13/16"	1-5/16"	ES-7/8	00982	01003	01024	01045	01066	01087					
1"	1/2"	2-13/16"	1-5/16"	ES-1	00983	01004	01025	01046	01067	01088					
1-1/4"	3/4"	3-3/8"	1-5/8"	ES-1-1/4	00984	01005	01026	01047	01068	01089					
1-1/2"	3/4"	3-1/2"	1-5/8"	ES-1-1/2	00985	01006	01027	01048	01069	01090					
1-3/4"	1"	4-1/4"	2-1/8"	ES-1-3/4	00987	01008	01029	01050	01071	01092					
2"	1"	4-3/8"	2-1/8"	ES-2	00988	01009	01030	01051	01072	01093					
2-1/2"	1"	4-3/4"	2-1/8"	ES-2-1/2	00989	01010	01031	01052	01073	01094					
3"	1"	5"	2-1/8"	ES-3	00990	01011	01032	01053	01074	01095					

#### Carbide

Head Dia.	Shank Dia.	Overall Length	Shank Length	Centerline Angle											
				30°		41°		45°		50°		55°		60°	
				Included Angle		60°		82°		90°		100°		110°	
				Severance Name	Order Number	Order Number	Order Number	Order Number	Order Number	Order Number	Order Number	Order Number	Order Number		
1/8"	1/8"	1-1/2"	1-1/2"	ES-1/8-W	01120	01135	01150	01165	01180	01195					
1/4"	3/16"	1-1/2"	1-3/16"	ES-1/4-W	01121	01136	01151	01166	01181	01196					
3/8"	1/4"	2-1/4"	1-3/4"	ES-3/8-W	01122	01137	01152	01167	01182	01197					
1/2"	3/8"	2-1/4"	1-3/4"	ES-1/2-W	01125	01140	01155	01170	01185	01200					
5/8"	3/8"	2-5/8"	2"	ES-5/8-W	01126	01141	01156	01171	01186	01201					
3/4"	1/2"	2-3/4"	2"	ES-3/4-W	01127	01142	01157	01172	01187	01202					
1"	1/2"	3"	2"	ES-1-W	01128	01143	01158	01173	01188	01203					



### 4-Flute Chatter-Free® Double Ended Econo-Sinks®

Severance 4-Flute chatter-free™ countersinks feature a 2+2 staggered cutting flute design. This tool provides lots of chip clearance and is ideal for non-ferrous materials including aluminum and plastics.

#### High Speed Steel

Head Dia.	Overall Length	Centerline Angle		30°	41°	45°	50°	55°	60°
		Included Angle		60°	82°	90°	100°	110°	120°
		Severance Name	Order Number	Order Number	Order Number	Order Number	Order Number	Order Number	
1/8"	1-1/2"	ES-1/8-DE	01204	01212	01220	01228	01236	01244	
3/16"	1-7/8"	ES-3/16-DE	01205	01213	01221	01229	01237	01245	
1/4"	2"	ES-1/4-DE	01206	01214	01222	01230	01238	01246	
5/16"	2-1/8"	ES-5/16-DE	01207	01215	01223	01231	01239	01247	
3/8"	2-1/2"	ES-3/8-DE	01208	01216	01224	01232	01240	01248	
1/2"	3"	ES-1/2-DE	01209	01217	01225	01233	01241	01249	
5/8"	3 -1/4"	ES-5/8-DE	01210	01218	01226	01234	01242	01250	
3/4"	3 -1/2"	ES-3/4-DE	01211	01219	01227	01235	01243	01251	

#### Carbide

Head Dia.	Overall Length	Centerline Angle		30°	41°	45°	50°	55°	60°
		Included Angle		60°	82°	90°	100°	110°	120°
		Severance Name	Order Number	Order Number	Order Number	Order Number	Order Number	Order Number	
1/8"	1-1/2"	ES-1/8-W-DE	01252	01260	01268	01276	01284	01292	
3/16"	2"	ES-3/16-W-DE	01253	01261	01269	01277	01285	01293	
1/4"	2"	ES-1/4-W-DE	01254	01262	01270	01278	01286	01294	
5/16"	2-1/8"	ES-5/16-W-DE	01255	01263	01271	01279	01287	01295	
3/8"	2-1/2"	ES-3/8-W-DE	01256	01264	01272	01280	01288	01296	
1/2"	3"	ES-1/2-W-DE	01257	01265	01273	01281	01289	01297	
5/8"	3 -1/4"	ES-5/8-W-DE	01258	01266	01274	01282	01290	01298	
3/4"	3-1/2"	ES-3/4-W-DE	01259	01267	01275	01283	01291	01299	



### Single Flute Double Ended Countersinks

Severance Single Flute Countersinks features our positive shear cutting edge. Single flutes are ideal for non-rigid machining applications, or for machines with less than precision spindles.

#### High Speed Steel

Head Dia.	Overall Length	Centerline Angle		30°	41°	45°	50°	55°	60°
		Included Angle		60°	82°	90°	100°	110°	120°
		Severance Name	Order Number	Order Number	Order Number	Order Number	Order Number	Order Number	
1/8"	1-1/2"	1/8-SF-DE	00536	00544	00552	00560	00568	00576	
3/16"	1-7/8"	3/16-SF-DE	00537	00545	00553	00561	00569	00577	
1/4"	2"	1/4-SF-DE	00538	00546	00554	00562	00570	00578	
5/16"	2-1/8"	5/16-SF-DE	00539	00547	00555	00563	00571	00579	
3/8"	2-1/2"	3/8-SF-DE	00540	00548	00556	00564	00572	00580	
1/2"	3"	1/2-SF-DE	00541	00549	00557	00565	00573	00581	
5/8"	3 -1/4"	5/8-SF-DE	00542	00550	00558	00566	00574	00582	
3/4"	3-1/2"	3/4-SF-DE	00543	00551	00559	00567	00575	00583	

#### Carbide

Head Dia.	Overall Length	Centerline Angle		30°	41°	45°	50°	55°	60°
		Included Angle		60°	82°	90°	100°	110°	120°
		Severance Name	Order Number	Order Number	Order Number	Order Number	Order Number	Order Number	
1/8"	1-1/2"	1/8-SF-W-DE	00600	00609	00617	00625	00633	00641	
3/16"	2"	3/16-SF-W-DE	00601	00610	00618	00626	00634	00642	
1/4"	2"	1/4-SF-W-DE	00602	00611	00619	00627	00635	00643	
5/16"	2-1/8"	5/16-SF-W-DE	00603	00612	00620	00628	00636	00644	
3/8"	2-1/2"	3/8-SF-W-DE	00604	00613	00621	00629	00637	00645	
1/2"	3"	1/2-SF-W-DE	00605	00614	00622	00630	00638	00646	
5/8"	3-1/4"	5/8-SF-W-DE	00606	00615	00623	00631	00639	00647	
3/4"	3-1/2"	3/4-SF-W-DE	00607	00616	00624	00632	00640	00648	

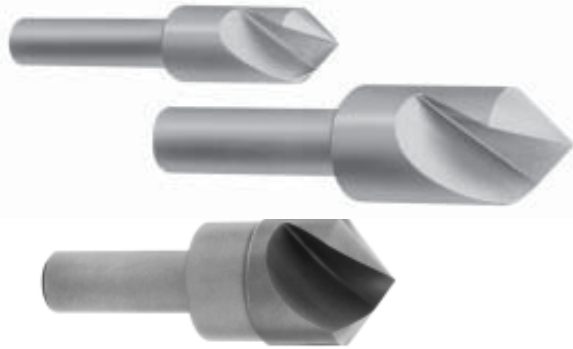

## Single Flute Countersinks

Single flute countersinks produce excellent results for light burr-free countersinking operations, are excellent at small hole chamfers, can operate at slightly higher RPM's, and may be reground many times. Other Diameters and angles can be provided as specials. Countersinks larger than 1" are not pointed, but have flat ends.

### High Speed Steel

Head Dia.	Shank Dia.	Overall Length	Shank Length	Centerline Angle											
				30°		41°		45°		50°		55°		60°	
				Included Angle		60°		82°		90°		100°		110°	
				Severance Name	Order Number	Order Number	Order Number	Order Number	Order Number	Order Number	Order Number	Order Number	Order Number		
1/8"	1/8"	1-5/8"	1-5/8"	1/8-SF	00270	00288	00306	00324	00342	00360					
3/16"	3/16"	1-1/2"	1-1/2"	3/16-SF	00271	00289	00307	00325	00343	00361					
1/4"	3/16"	1-1/2"	3/4"	1/4-SF	00272	00290	00308	00326	00344	00362					
5/16"	1/4"	1-3/4"	7/8"	5/16-SF	00273	00291	00309	00327	00345	00363					
3/8"	1/4"	1-3/4"	7/8"	3/8-SF	00274	00292	00310	00328	00346	00364					
1/2"	3/8"	2-1/8"	1-1/8"	1/2-SF	00275	00293	00311	00329	00347	00365					
1/2"	1/4"	2-1/8"	1-1/8"	1/2-SF-1/4	00276	00294	00312	00330	00348	00366					
5/8"	3/8"	2-3/8"	1-1/8"	5/8-SF	00277	00295	00313	00331	00349	00367					
5/8"	1/4"	2-3/8"	1-1/8"	5/8-SF-1/4	00278	00296	00314	00332	00350	00368					
3/4"	1/2"	2-11/16"	1-5/16"	3/4-SF	00279	00297	00315	00333	00351	00369					
7/8"	1/2"	2-13/16"	1-5/16"	7/8-SF	00280	00298	00316	00334	00352	00370					
1"1/2"	2-13/16"	1-5/16"	1-SF	00281	00299	00317	00335	00353	00371						
1-1/4"	3/4"	3-3/8"	1-5/8"	1-1/4-SF	00282	00300	00318	00336	00354	00372					
1-1/2"	3/4"	3-1/2"	1-5/8"	1-1/2-SF	00283	00301	00319	00337	00355	00373					
1-3/4"	1"	4-1/4"	2-1/8"	1-3/4-SF	00284	00302	00320	00338	00356	00374					
2"	1"	4-3/8"	2-1/8"	2-SF	00285	00303	00321	00339	00357	00375					
2-1/2"	1"	4-3/4"	2-1/8"	2-1/2-SF	00286	00304	00322	00340	00358	00376					
3"	1"	5"	2-1/8"	3-SF	00287	00305	00323	00341	00359	00377					

### Carbide

Head Dia.	Shank Dia.	Overall Length	Shank Length	Centerline Angle											
				30°		41°		45°		50°		55°		60°	
				Included Angle		60°		82°		90°		100°		110°	
				Severance Name	Order Number	Order Number	Order Number	Order Number	Order Number	Order Number	Order Number	Order Number	Order Number		
1/8"	1/8"	1-1/2"	1-1/2"	1/8-SF-W	00420	00440	00460	00480	00500	00520					
3/16"	3/16"	1-1/2"	1-1/2"	3/16-SF-W	00421	00441	00461	00481	00501	00521					
1/4"	3/16"	1-1/2"	1-1/16"	1/4-SF-W	00422	00442	00462	00482	00502	00522					
5/16"	1/4"	1-3/4"	1-5/8"	5/16-SF-W	00423	00443	00463	00483	00503	00523					
3/8"	1/4"	1-3/4"	1-7/16"	3/8-SF-W	00424	00444	00464	00484	00504	00524					
1/2"	3/8"	2-1/8"	1-3/8"	1/2-SF-W	00425	00445	00465	00485	00505	00525					
1/2"	1/4"	2-1/8"	1-3/8"	1/2-SF-W-1/4	00426	00446	00466	00486	00506	00526					
5/8"	3/8"	2-3/8"	1-5/16"	5/8-SF-W	00427	00447	00467	00487	00507	00527					
5/8"	1/4"	2-3/8"	1-21/64"	5/8-SF-W-1/4	00428	00448	00468	00488	00508	00528					
3/4"	1/2"	2-11/16"	1-5/16"	3/4-SF-W	00429	00449	00469	00489	00509	00529					
7/8"	1/2"	2-13/16"	1-5/16"	7/8-SF-W	00430	00450	00470	00490	00510	00530					
1"	1/2"	2-13/16"	1-5/16"	1-SF-W	00431	00451	00471	00491	00511	00531					
1-1/4"	3/4"	3-3/8"	1-5/8"	1-1/4-SF-W	00432	00452	00472	00492	00512	00532					
1-1/2"	3/4"	3-1/2"	1-5/8"	1-1/2-SF-W	00433	00453	00473	00493	00513	00533					
1-3/4"	1"	4-1/4"	2-1/8"	1-3/4-SF-W	00434	00454	00474	00494	00514	00534					
2"	1"	4-3/8"	2-1/8"	2-SF-W	00435	00455	00475	00495	00515	00535					



**High Speed Steel**

**AC-Adjustable Countersinks**

Severance AC Countersinks are designed out of high speed steel as an economical means of combining drilling and countersinking into a continuous operation. They are well adapted to a wide range of applications, and can be used for countersinking wood or light metals, such as mild steel, magnesium, brass and die cast, and for some plastics.

They can be used with any standard twist drill in sizes as indicated, so they need not be discarded if the drill breaks or is used up. They can be positioned at any point along the fluted section of a drill and work best if adjusted to start countersinking when the drilling has been completed.

The cutting teeth are arranged to give a shearing cut, to produce a seat free from chatter and to avoid corkscrew jamming.

These Tools can be factory resharpened many times for cost efficiency. See pages 89-90 for more details.

**Drill not included.**

C'Sink Body Dia.	Drill Size	Overall Length	Centerline Angle		
			Included Angle	41°	45°
			82°	82°	90°
			Severance Name	Order Number	Order Number
3/8"	1/8" (.1250)	1"	6-AC-2	03572	03622
3/8"	29 (.1360)	1"	6-AC-29	03573	03623
3/8"	28 (.1405)	1"	6-AC-28	03574	03624
3/8"	25 (.1495)	1"	6-AC-25	03575	03625
3/8"	21 (.1590)	1"	6-AC-21	03576	03626
3/8"	19 (.1660)	1"	6-AC-19	03577	03627
1/2"	16 (.1770)	1-1/8"	8-AC-16	03579	03629
1/2"	14 (.1820)	1-1/8"	8-AC-14	03580	03630
1/2"	3/16" (.1875)	1-1/8"	8-AC-3/16	03578	03628
1/2"	10 (.1935)	1-1/8"	8-AC-10	03582	03632
1/2"	7 (.2010)	1-1/8"	8-AC-7	03583	03633
1/2"	7/32" (.2188)	1-1/8"	8-AC-7/32	03581	03631
5/8"	3 (.2130)	1-1/8"	10-AC-3	03586	03636
5/8"	7/32" (.2188)	1-1/8"	10-AC-7/32	03584	03634
5/8"	2 (.2210)	1-1/8"	10-AC-2	03587	03637
5/8"	D (.2460)	1-1/8"	10-AC-D	03590	03640
5/8"	1/4" (.2500)	1-1/8"	10-AC-4	03585	03635
5/8"	F (.2570)	1-1/8"	10-AC-F	03603	03604
5/8"	I (.2720)	1-1/8"	10-AC-I	03591	03641
5/8"	9/32" (.2813)	1-1/8"	10-AC-9/32	03588	03638
5/8"	5/16" (.3125)	1-1/8"	10-AC-5/16	03589	03639
7/8"	Q (.3320)	1-1/2"	14-AC-Q	03592	03642
7/8"	R (.3390)	1-1/2"	14-AC-R	03593	03643
7/8"	S (.3480)	1-1/2"	14-AC-S	03594	03644
7/8"	U (.3680)	1-1/2"	14-AC-U	03596	03646
7/8"	3/8" (.3750)	1-1/2"	14-AC-3/8	03595	03645
7/8"	25/64" (.3906)	1-1/2"	14-AC-25/64	03597	03647
1-1/8"	27/64" (.4219)	1-3/4"	18-AC-27/64	03598	03648
1-1/8"	7/16" (.4375)	1-3/4"	18-AC-7/16	03599	03649
1-1/8"	29/64" (.4531)	1-3/4"	18-AC-29/64	03600	03650
1-1/8"	31/64" (.4844)	1-3/4"	18-AC-31/64	03602	03652
1-1/8"	1/2" (.5000)	1-3/4"	18-AC-1/2	03601	03651

**Special Adjustable Countersinks**

Special diameters, drill sizes, flute configurations, and angles are available as specials. This Adjustable countersink is designed for non-ferrous materials such as aluminum and magnesium.



REF. # 55381

## Micrometer Stop-Countersink Units

The Micrometer Micro Stop-Countersink Unit was invented and patented (USP 3028774) by Severance Tool for the aircraft industry to allow precise depth control countersinking and deburring. These units ensure perpendicular alignment with the workpiece and easy to adjust exact depth control in increments of .001". They feature hardened and ground spindles supported by ball bearings, bronze sleeves, or needle bearings, and thrust bearings, and a lock nut to maintain "preset" depth dimensions. Overhang is at a minimum making it possible to work in close quarters.

These units are still widely used in Aircraft manufacturing and maintenance, in sheet metal part production areas, and have found wide use in Transportation, electronic, medical, defense, and telecommunications where precise depth control countersinking is required. Used in hand drills, drill presses, mills, lathes, etc. Bases can be modified for special applications or contours. See "NEW" high speed roller bearing units RSC-24 & RSC-36.

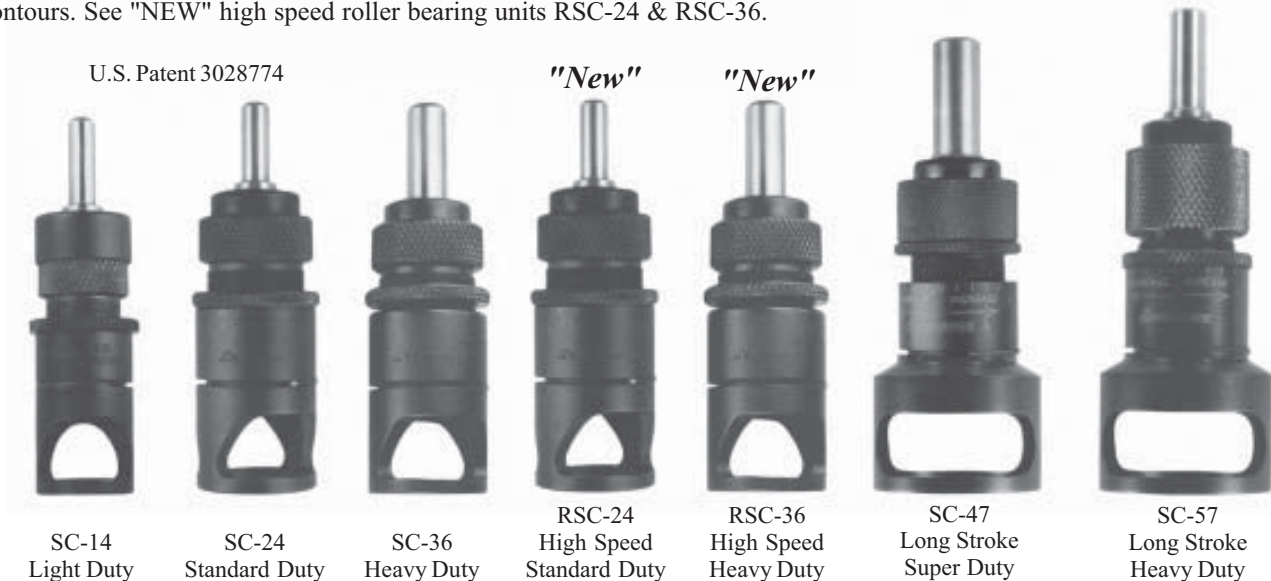

Recommended Maximum Cutter	Unit Shank Dia.	Standard Outside Dia.	Overall Length Retracted	Overall Length Extended	Length of Stroke	Internal Thread	Severance Tool Name	EDP Order Number
7/16"	1/4"	7/8"	3.243"	3.544"	.180	1/4"-28	SC-14	21220
3/4"	1/4"	1-1/16"	3.265"	3.513"	.180	1/4"-28	SC-24	21221
3/4"	1/4"	1-1/16"	3.265"	3.513"	.180	1/4"-28	RSC-24	21227
3/4"	3/8"	1-1/16"	3.310"	3.521"	.180	3/8"-24	SC-36	21222
3/4"	3/8"	1-1/16"	3.310"	3.521"	.180	3/8"-24	RSC-36	21228
1-1/4"	1/2"	1-3/4"	4.270"	4.715"	.280	7/16"-20	SC-47	21223
1-1/4"	3/8"	1-3/4"	4.700"	5.185"	.280	3/8"-24	SC-57	21224



**Special Override Micro-Stop Countersink Units Available by Application**

Non-Marking Nylon Foot	Maximum Cutting Diameter With Foot	Part Number	EDP Number
	7/16"	SC-14-11	21245
5/8"	SC-24-11	21264	
1-1/4"	SC-36-11	21264	
1-1/4"	SC-47-11	21302	

**Special units and cutters can be made to fit customers applications**

A Severance Precision Stop Countersink Unit is designed for hand power-tool and drill-press use.

This unit converts your drill-press into a precision countersinking unit, giving you identical countersinks on parts of various thicknesses.



**#2 Morse Taper Adapter for SC-47 Unit**

Part No.	EDP No.
FM-4-MT	34238

If adapter is ordered at the same time as SC-47 UNIT, unit will be provided with a whistle notch.

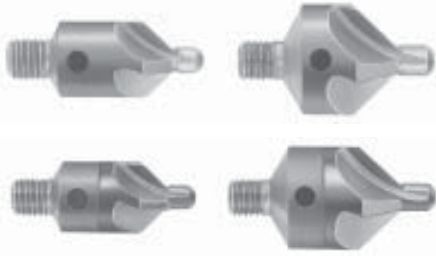

## Chatter-Free® Stop-Countersinks Cutters

Also known as Aircraft style Stop-Countersinks. These tools feature our patented 4 flute Chatter-Free® flute design for smooth finishes, fast production, and quick chip removal. These precision ground tools are made from High Speed Steel or Carbide and may be factory resharpened many times for long useful tool life. Also available with special pilot sizes, angles, forms, and no pilots upon request.

### High Speed Steel

Head Dia.	Pilot Dia.	Thread Dia.	Overall Length	Centerline Angle					
				30°		41°	45°	50°	60°
				Included Angle		60°	82°	90°	100°
			Severance Name	Order Number	Order Number	Order Number	Order Number	Order Number	
3/8"	3/32 (.0938)	1/4"-28	1-5/32"	SC-6	15340	15485	15629	15774	15919
3/8"	#40 (.0980)	1/4"-28	1-5/32"	SC-6	15341	15486	15630	15775	15920
3/8"	1/8 (.1250)	1/4"-28	1-5/32"	SC-6	15342	15487	15631	15776	15921
3/8"	#30 (.1285)	1/4"-28	1-5/32"	SC-6	15343	15488	15632	15777	15922
3/8"	5/32 (.1562)	1/4"-28	1-5/32"	SC-6	15345	15489	15634	15779	15924
3/8"	#21 (.1590)	1/4"-28	1-5/32"	SC-6	15346	15490	15635	15780	15925
3/8"	3/16 (.1875)	1/4"-28	1-5/32"	SC-6	15347	15491	15636	15781	15926
3/8"	#10 (.1935)	1/4"-28	1-5/32"	SC-6	15348	15492	15637	15782	15927
7/16"	3/32 (.0938)	1/4"-28	1-5/32"	SC-7	15350	15494	15639	15784	15929
7/16"	#40 (.0980)	1/4"-28	1-5/32"	SC-7	15351	15495	15640	15785	15930
7/16"	1/8 (.1250)	1/4"-28	1-5/32"	SC-7	15352	15496	15641	15786	15931
7/16"	#30 (.1285)	1/4"-28	1-5/32"	SC-7	15353	15497	15642	15787	15932
7/16"	5/32 (.1562)	1/4"-28	1-5/32"	SC-7	15355	15499	15644	15789	15934
7/16"	#21 (.1590)	1/4"-28	1-5/32"	SC-7	15356	15500	15645	15790	15935
7/16"	3/16 (.1875)	1/4"-28	1-5/32"	SC-7	15357	15501	15646	15791	15936
7/16"	#10 (.1935)	1/4"-28	1-5/32"	SC-7	15358	15502	15647	15792	15937
1/2"	3/32 (.0938)	1/4"-28	1-5/32"	SC-8	15360	15504	15649	15794	15939
1/2"	#40 (.0980)	1/4"-28	1-5/32"	SC-8	15361	15505	15650	15795	15940
1/2"	1/8 (.1250)	1/4"-28	1-5/32"	SC-8	15362	15506	15651	15796	15941
1/2"	#30 (.1285)	1/4"-28	1-5/32"	SC-8	15363	15507	15652	15797	15942
1/2"	5/32 (.1562)	1/4"-28	1-5/32"	SC-8	15364	15508	15653	15798	15943
1/2"	#21 (.1590)	1/4"-28	1-5/32"	SC-8	15366	15510	15655	15800	15945
1/2"	3/16 (.1875)	1/4"-28	1-5/32"	SC-8	15367	15511	15656	15801	15946
1/2"	#10 (.1935)	1/4"-28	1-5/32"	SC-8	15368	15512	15657	15802	15947
1/2"	7/32 (.2187)	1/4"-28	1-5/32"	SC-8	15369	15513	15658	15803	15948
1/2"	1/4 (.2500)	1/4"-28	1-5/32"	SC-8	15370	15514	15659	15804	15949
5/8"	1/8 (.1250)	1/4"-28	1-5/32"	SC-10	15372	15516	15661	15806	15951
5/8"	#30 (.1285)	1/4"-28	1-5/32"	SC-10	15373	15517	15662	15807	15952
5/8"	5/32 (.1562)	1/4"-28	1-5/32"	SC-10	15374	15518	15663	15808	15953
5/8"	#21 (.1590)	1/4"-28	1-5/32"	SC-10	15375	15519	15664	15809	15954
5/8"	3/16 (.1875)	1/4"-28	1-5/32"	SC-10	15376	15520	15665	15810	15955
5/8"	#10 (.1935)	1/4"-28	1-5/32"	SC-10	15378	15522	15667	15812	15957
5/8"	7/32 (.2187)	1/4"-28	1-5/32"	SC-10	15379	15523	15668	15813	15958
5/8"	1/4 (.2500)	1/4"-28	1-5/32"	SC-10	15380	15524	15669	15814	15959
5/8"	5/16 (.3125)	1/4"-28	1-5/32"	SC-10	15381	15525	15670	15815	15960
5/8"	3/8 (.3750)	1/4"-28	1-5/32"	SC-10	15382	15526	15671	15816	15961
3/4"	5/32 (.1562)	1/4"-28	1-3/16"	SC-12	15384	15528	15673	15818	15963
3/4"	#21 (.1590)	1/4"-28	1-3/16"	SC-12	15385	15529	15674	15819	15964
3/4"	3/16 (.1875)	1/4"-28	1-3/16"	SC-12	15386	15530	15675	15820	15965
3/4"	#10 (.1935)	1/4"-28	1-3/16"	SC-12	15387	15531	15676	15821	15966
3/4"	7/32 (.2187)	1/4"-28	1-3/16"	SC-12	15389	15533	15678	15823	15968
3/4"	1/4 (.2500)	1/4"-28	1-3/16"	SC-12	15390	15534	15679	15824	15969
3/4"	"F" (.2570)	1/4"-28	1-3/16"	SC-12	15391	15535	15680	15825	15970
3/4"	5/16 (.3125)	1/4"-28	1-3/16"	SC-12	15392	15536	15681	15826	15971
3/4"	3/8 (.3750)	1/4"-28	1-3/16"	SC-12	15393	15537	15682	15827	15972
3/4"	5/32 (.1562)	3/8"-24	1-3/16"	S3-12	15395	15539	15684	15829	15974
3/4"	#21 (.1590)	3/8"-24	1-3/16"	S3-12	15396	15540	15685	15830	15975

**Chatter-Free™ Stop-Countersinks Cutters continued....**



**High Speed Steel**

Head Dia.	Pilot Dia.	Thread Dia.	Overall Length	Centerline Angle							
				30°		41°		50°		60°	
				Included Angle		60°		82°		90°	
Severance Name		Order Number	Order Number	Order Number	Order Number	Order Number	Order Number				
3/4"	3/16 (.1875)	3/8"-24	1-3/16"	S3-12	15397	15541	15686	15831	15976		
3/4"	#10 (.1935)	3/8"-24	1-3/16"	S3-12	15398	15542	15687	15832	15977		
3/4"	7/32 (.2187)	3/8"-24	1-3/16"	S3-12	15400	15544	15689	15834	15979		
3/4"	1/4 (.2500)	3/8"-24	1-3/16"	S3-12	15401	15545	15690	15835	15980		
3/4"	"F" (.2570)	3/8"-24	1-3/16"	S3-12	15402	15546	15691	15836	15981		
3/4"	5/16 (.3125)	3/8"-24	1-3/16"	S3-12	15403	15547	15692	15837	15982		
3/4"	3/8 (.3750)	3/8"-24	1-3/16"	S3-12	15404	15548	15693	15838	15983		
1-1/4"	3/16 (.1875)	7/16"-20	1-3/8"	SC-20	15406	15550	15695	15840	15985		
1-1/4"	#10 (.1935)	7/16"-20	1-3/8"	SC-20	15407	15551	15696	15841	15986		
1-1/4"	7/32 (.2187)	7/16"-20	1-3/8"	SC-20	15408	15552	15697	15842	15987		
1-1/4"	1/4 (.2500)	7/16"-20	1-3/8"	SC-20	15409	15553	15698	15843	15988		
1-1/4"	"F" (.2570)	7/16"-20	1-3/8"	SC-20	15411	15555	15700	15845	15990		
1-1/4"	5/16 (.3125)	7/16"-20	1-3/8"	SC-20	15412	15556	15701	15846	15991		
1-1/4"	3/8 (.3750)	7/16"-20	1-3/8"	SC-20	15413	15557	15702	15847	15992		
1-1/4"	1/2 (.5000)	7/16"-20	1-3/8"	SC-20	15414	15558	15703	15848	15993		



**Carbide**

Head Dia.	Pilot Dia.	Thread Dia.	Overall Length	Centerline Angle							
				30°		41°		50°		60°	
				Included Angle		60°		82°		90°	
Severance Name		Order Number	Order Number	Order Number	Order Number	Order Number	Order Number				
3/8"	3/32 (.0938)	1/4"-28	1-5/32"	SC-6-W	13840	13985	14129	14274	14419		
3/8"	#40 (.0980)	1/4"-28	1-5/32"	SC-6-W	13841	13986	14130	14275	14420		
3/8"	1/8 (.1250)	1/4"-28	1-5/32"	SC-6-W	13842	13987	14131	14276	14421		
3/8"	#30 (.1285)	1/4"-28	1-5/32"	SC-6-W	13843	13988	14132	14277	14422		
3/8"	5/32 (.1562)	1/4"-28	1-5/32"	SC-6-W	13845	13989	14134	14279	14424		
3/8"	#21 (.1590)	1/4"-28	1-5/32"	SC-6-W	13846	13990	14135	14280	14425		
3/8"	3/16 (.1875)	1/4"-28	1-5/32"	SC-6-W	13847	13991	14136	14281	14426		
3/8"	#10 (.1935)	1/4"-28	1-5/32"	SC-6-W	13848	13992	14137	14282	14427		
7/16"	3/32 (.0938)	1/4"-28	1-5/32"	SC-7-W	13850	13994	14139	14284	14429		
7/16"	#40 (.0980)	1/4"-28	1-5/32"	SC-7-W	13851	13995	14140	14285	14430		
7/16"	1/8 (.1250)	1/4"-28	1-5/32"	SC-7-W	13852	13996	14141	14286	14431		
7/16"	#30 (.1285)	1/4"-28	1-5/32"	SC-7-W	13853	13997	14142	14287	14432		
7/16"	5/32 (.1562)	1/4"-28	1-5/32"	SC-7-W	13855	13999	14144	14289	14434		
7/16"	#21 (.1590)	1/4"-28	1-5/32"	SC-7-W	13856	14000	14145	14290	14435		
7/16"	3/16 (.1875)	1/4"-28	1-5/32"	SC-7-W	13857	14001	14146	14291	14436		
7/16"	#10 (.1935)	1/4"-28	1-5/32"	SC-7-W	13858	14002	14147	14292	14437		
1/2"	3/32 (.0938)	1/4"-28	1-5/32"	SC-8-W	13860	14004	14149	14294	14439		
1/2"	#40 (.0980)	1/4"-28	1-5/32"	SC-8-W	13861	14005	14150	14295	14440		
1/2"	1/8 (.1250)	1/4"-28	1-5/32"	SC-8-W	13862	14006	14151	14296	14441		
1/2"	#30 (.1285)	1/4"-28	1-5/32"	SC-8-W	13863	14007	14152	14297	14442		
1/2"	5/32 (.1562)	1/4"-28	1-5/32"	SC-8-W	13864	14008	14153	14298	14443		
1/2"	#21 (.1590)	1/4"-28	1-5/32"	SC-8-W	13866	14010	14155	14300	14445		
1/2"	3/16 (.1875)	1/4"-28	1-5/32"	SC-8-W	13867	14011	14156	14301	14446		
1/2"	#10 (.1935)	1/4"-28	1-5/32"	SC-8-W	13868	14012	14157	14302	14447		
1/2"	7/32 (.2187)	1/4"-28	1-5/32"	SC-8-W	13869	14013	14158	14303	14448		
1/2"	1/4 (.2500)	1/4"-28	1-5/32"	SC-8-W	13870	14014	14159	14304	14449		
5/8"	1/8 (.1250)	1/4"-28	1-5/32"	SC-10-W	13872	14016	14161	14306	14451		
5/8"	#30 (.1285)	1/4"-28	1-5/32"	SC-10-W	13873	14017	14162	14307	14452		
5/8"	5/32 (.1562)	1/4"-28	1-5/32"	SC-10-W	13874	14018	14163	14308	14453		
5/8"	#21 (.1590)	1/4"-28	1-5/32"	SC-10-W	13875	14019	14164	14309	14454		
5/8"	3/16 (.1875)	1/4"-28	1-5/32"	SC-10-W	13876	14020	14165	14310	14455		
5/8"	#10 (.1935)	1/4"-28	1-5/32"	SC-10-W	13878	14022	14167	14312	14457		

See more sizes page 67

## Chatter-Free™ Stop-Countersinks Cutters continued....



### Carbide

Head Dia.	Pilot Dia.	Thread Dia.	Overall Length	Centerline Angle		30°	41°	45°	50°	60°
				Included Angle		60°	82°	90°	100°	120°
				Severance Name	Order Number	Order Number	Order Number	Order Number	Order Number	
5/8"	7/32 (.2187)	1/4"-28	1-5/32"	SC-10-W	13879	14023	14168	14313	14458	
5/8"	1/4 (.2500)	1/4"-28	1-5/32"	SC-10-W	13880	14024	14169	14314	14459	
5/8"	5/16 (.3125)	1/4"-28	1-5/32"	SC-10-W	13881	14025	14170	14315	14460	
5/8"	3/8 (.3750)	1/4"-28	1-5/32"	SC-10-W	13882	14026	14171	14316	14461	
3/4"	5/32 (.1562)	3/8"-24	1-3/16"	S3-12-W	13895	14039	14184	14329	14474	
3/4"	#21 (.1590)	3/8"-24	1-3/16"	S3-12-W	13896	14040	14185	14330	14475	
3/4"	3/16 (.1875)	3/8"-24	1-3/16"	S3-12-W	13897	14041	14186	14331	14476	
3/4"	#10 (.1935)	3/8"-24	1-3/16"	S3-12-W	13898	14042	14187	14332	14477	
3/4"	7/32 (.2187)	3/8"-24	1-3/16"	S3-12-W	13900	14044	14189	14334	14479	
3/4"	1/4 (.2500)	3/8"-24	1-3/16"	S3-12-W	13901	14045	14190	14335	14480	
3/4"	"F" (.2570)	3/8"-24	1-3/16"	S3-12-W	13902	14046	14191	14336	14481	
3/4"	5/16 (.3125)	3/8"-24	1-3/16"	S3-12-W	13903	14047	14192	14337	14482	
3/4"	3/8 (.3750)	3/8"-24	1-3/16"	S3-12-W	13904	14048	14193	14338	14483	

## Aircraft Style Rivet Shavers

Severance Rivet Shavers are used with Micro-Stop units. These end-cutting tools are designed to cut rivet heads, etc., flush to the surrounding surface. They are available in two series, multi-flute for fine finishing and two-flute for fast material removal.

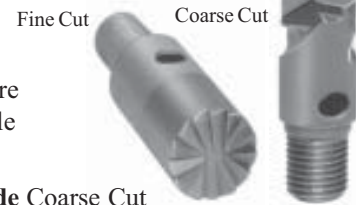

### Carbide Fine Cut

Tool Dia.	Overall Length	Thread Size
5/16"	27/32"	1/4"-28
3/8"	27/32"	1/4"-28
7/16"	27/32"	1/4"-28
1/2"	27/32"	1/4"-28
9/16"	27/32"	1/4"-28
5/8"	27/32"	1/4"-28
3/4"	31/32"	3/8"-24
7/8"	31/32"	3/8"-24
1"	31/32"	3/8"-24

Number of Flutes	Severance Tool Name	EDP Order Number
14	RS-11	28480
14	RS-12	28481
14	RS-13	28482
14	RS-14	28483
16	RS-15	28484
16	RS-16	28485
18	RS-37	28486
24	RS-38	28487
24	RS-39	28488

### Carbide Coarse Cut

Number of Flutes	Severance Tool Name	EDP Order Number
2	RS-21	28490
2	RS-22	28491
2	RS-23	28492
2	RS-24	28493
2	RS-25	28494
2	RS-26	28495
2	RS-47	28496
2	RS-48	28497
2	RS-49	28498

## Special Stop-Countersinks and Units

Special diameters, pilots, flutes, and threads available on the stop countersinks. Special Units can be made like this vacuum unit pictured here.

See pages 41 and 80 for handles



REF. # 55370