



H.S.S.
Midget-Mill®
Single Cut
Chip Breakers



Shape V Midget Mills®

Convex with cutting teeth on the radius only.

Head Dia.	Flute Length	Radius	Severance Tool Name	EDP Order Number
1/4"	3/8"	1/4"	CEV	23206
5/8"	7/16"	1/4"	IFV	23207
3/4"	1/2"	1/2"	JGV	23208
1"	3/16"	3/32"	LBV	23209
1-1/4"	7/8"	5/8"	NKV	23210

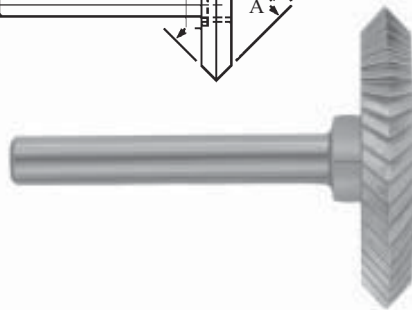
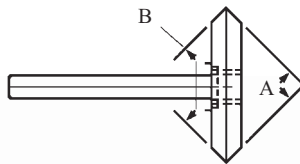

H.S.S.
Midget-Mill®
Single Cut
Chip Breakers



Shape X Midget Mill®

Convex shape mills. This shape combines forward and reverse angles as listed in the "Included Angle" column. Forward angle is given first, followed by reverse angle. Angles are given with C/L. Special angles may be obtained at a nominal extra charge.

Head Dia.	Head Length	Centerline Angles		Severance Tool Name	EDP Order Number
		A	B		
1/4"	1/4"	20°	20°	CCX	23221
1/4"	3/8"	80°	10°	CEX	23217
5/16"	1/4"	30°	30°	DCX	23222
3/8"	1/4"	60°	60°	ECX	23223
1/2"	1/4"	50°	50°	GCX	23224
5/8"	1/4"	60°	60°	ICX	23225
5/8"	5/8"	40°	20°	IIX	23218
3/4"	1/2"	120°	60°	JGX	23219
1"	1/4"	90°	90°	LCX	23226
1"	3/4"	90°	30°	LJX	23220
1-1/2"	1/4"	60°	60°	PCX-30	23227
1-1/2"	1/4"	90°	90°	PCX-45	23228
1-1/2"	1/4"	120°	120°	PCX-60	23229



H.S.S.
Midget-Mill®
Single Cut
Chip Breakers



Shape W Midget Mills®

Cylindrical shape mills with cutting teeth on the end radius only. They feature a non-fluted (safe) area at the center of the end face and on the straight cylindrical sides adjacent to the radius. Use for finishing fillets and many other similar applications.

Head Dia.	Flute Length	Radius	Severance Tool Name	EDP Order Number
1/4"	1/8"	1/16"	CAW	23211
5/16"	1/4"	1/16"	DCW	23212
3/8"	5/16"	3/32"	ECW	23213
1/2"	3/8"	5/32"	GEW	23214
7/8"	1/2"	1/4"	KGW	23215
1"	1/2"	5/16"	LGW	23216



H.S.S.
Midget-Mill®
Single Cut
Chip Breakers



Shape BI Midget Mills®

Convex with cutting teeth on the radius only.

Head Dia.	Flute Length	Radius	Severance Tool Name	EDP Order Number
3/16"	5/8"	5/16" x 1/2"	BIRU	23230
1/4"	3/4"	1-1/2" x 1/2"	CJCU	23231
1/4"	1"	3/4" x 3/4"	CLRU	23232
1/4"	1"	1" x 1/2"	CLTU	23233
5/16"	1-1/8"	1" x 1"	DMRU	23234
3/8"	1"	3/16" x 1-1/4"	ELCU	23235
3/8"	1"	1/2" x 3/4"	ELTU	23236
1/2"	7/8"	1/4" x 3/8"	GKCU	23237



Shape FL Midget Mills®

A very handy shape for blending operations.

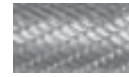

Carbide
Carbo-Mill™
Double Cut

Head Dia.	Flute Length	Midget Mill® Name	EDP Order Number	Carbo-Mill™ Name	EDP Order Number
1/4"	5/8"	CIFL-W	23367	8GN-W	22415
5/16"	3/4"	DJFL-W	23368	10FL8-W	22569
1/2"	1-1/4"	GNFL-W	23369	16FL8-W	22570
5/8"	1-7/16"	IOFL-W	23370	20FL8-W	22571
3/4"	1-5/8"	JQFL-W	23371	24FL8-W	22572